

# Thermaclass

Cavity Wall 21

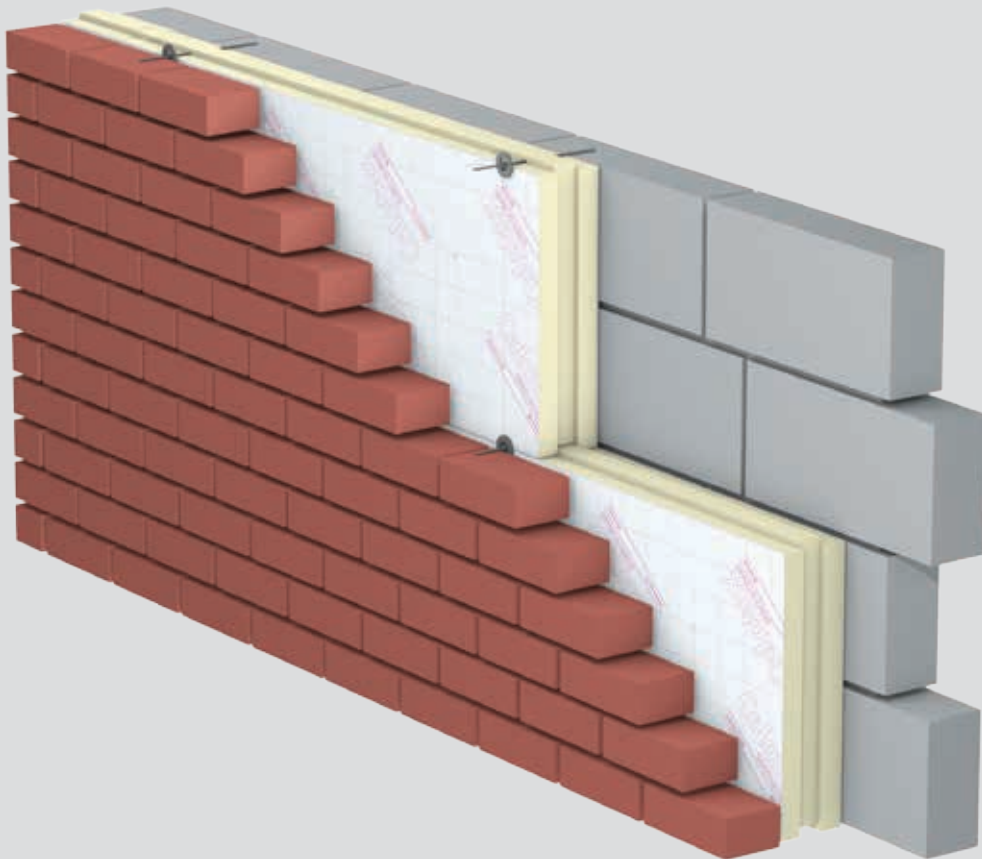

---

Installation Guide

---

# Thermaclass Cavity Wall 21 Installation Guide

Thermaclass Cavity Wall 21 is an easy to install, high thermal performance polyisocyanurate (PIR) insulation board for full fill cavity wall applications, with a thermal conductivity of 0.021 W/m.K. It can be installed with up to a 10mm residual cavity (to support ease of installation and accommodate mortar squeeze) or as a full fill solution with no residual cavity.

The boards feature an engineered tongue and groove joint profile, helping to ensure a continuous layer of insulation to maximise thermal performance and provide protection from wind driven rain.

## Key Considerations

When using Thermaclass Cavity Wall 21, you need to satisfy yourself that use of the product meets all relevant national Building Regulations and guidance as well as local, national and other applicable standards relevant for your construction or application, including requirements in relation to fire and applicable height restrictions.

Please refer to the following product documents which are available at [insulation-uk.com/thermaclass](https://insulation-uk.com/thermaclass) (product properties) and [insulation-uk.com/healthandsafety](https://insulation-uk.com/healthandsafety) (safety properties):

- BBA certificate
- Product datasheet
- Declaration of Performance
- Health & safety datasheet

Thermaclass Cavity Wall 21 should not be used in the external walls of buildings over 18 metres in height (England and Wales) or 11 metres in height (Scotland). Recent changes to Building Regulations mean that only non-combustible insulation or insulation of limited combustibility can be used in buildings of that height.

## Size and Dimensions

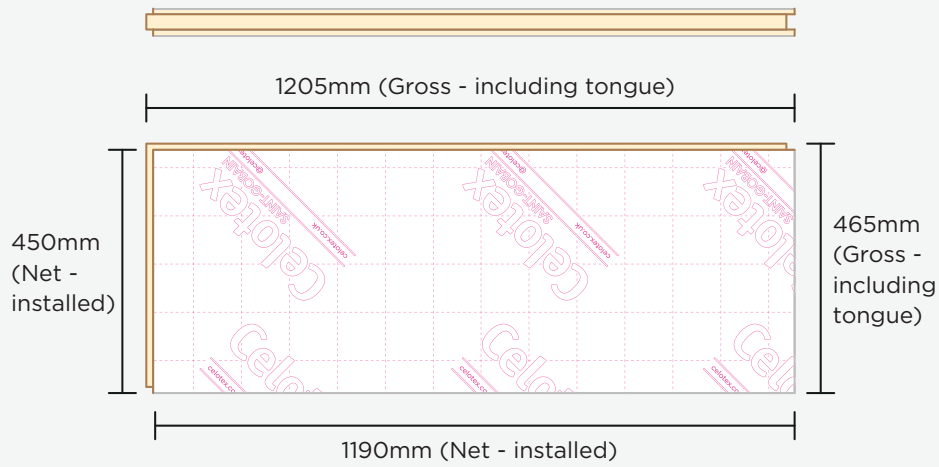

FIGURE 1A -  
BOARD DIMENSIONS

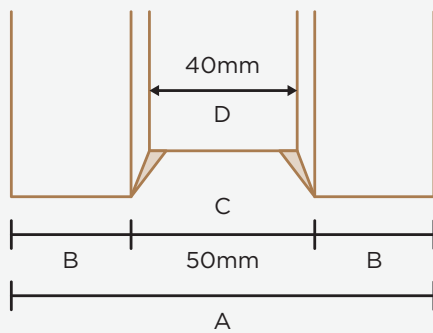

FIGURE 1B -  
GROOVE PROFILE

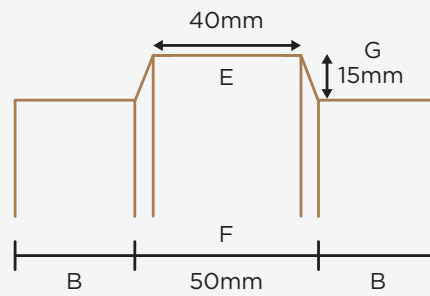

FIGURE 1C -  
TONGUE PROFILE

### Edge profile dimensions

Board thickness mm (A)	90	115	140	Top of tongue mm (E)	40	40	40
Outer edges mm (B)	20	32.5	45	Base of tongue mm (F)	50	50	50
Outer groove mm (C)	50	50	50	Tongue height mm (G)	15	15	15
Inner groove mm (D)	40	40	40				

## Installation

1. Build up the first section of the internal wall leaf.
2. Install the first row of wall ties at a minimum of one course of blockwork below the Damp Proof Course (DPC). Reference should be made to Eurocode 6, BS EN 845-1 and Building Regulations Approved Document A for further guidance on wall ties and masonry wall construction.
3. The Thermaclass Cavity Wall 21 boards should be positioned with the tongue at the top of the board. When planning the installation, it should be decided whether the tongue should appear on the 'top and left' or 'top and right' of the boards and maintain this defined orientation throughout the installation.

Please be aware that in doing this, some boards will feature the branded foil facer facing outward and some the unbranded facer. This is not an issue as there is no performance variation between these facers.

4. Before installing the Thermaclass Cavity Wall 21 insulation board:
  - a. Identify where the wall ties will land on the tongue side of the board.
  - b. Using a self-retracting knife, cut the facer then use a sharp specialist insulation saw to make the final small incision in the tongue profile, with a tilt to follow the downward facing direction from the inner leaf to the outer leaf (see Figures 2 & 3).
  - c. The incision should not be more than 15mm deep.

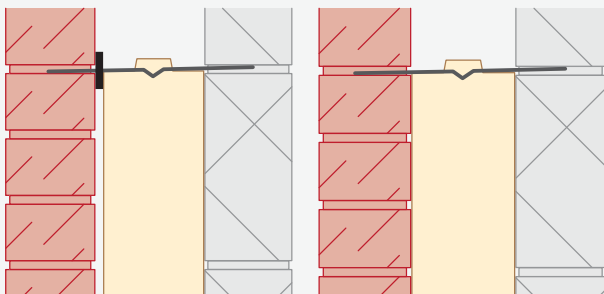

FIGURE 2 - WITH RESIDUAL CAVITY

FIGURE 3 - WITHOUT RESIDUAL CAVITY

- d. When there is a residual cavity, all ties should include a retaining clip or disc as appropriate to ensure boards are secured in place against the internal wall leaf (see Figure 2).
5. The first row of the Thermaclass Cavity Wall 21 insulation boards should be supported by the first row of wall ties. Fit the boards flush against the internal leaf, maintaining up to a 10mm residual cavity where specified between the insulation board and the external wall leaf. The boards should be installed to an engineer's requirement or to a minimum depth of 150mm below the damp proof course (DPC) to provide edge insulation to the floor and reduce thermal bridging at this junction. Ensure that the Thermaclass Cavity Wall 21 insulation boards are not in contact with the ground or that all board edges are sealed.
6. The next board is then fitted tightly to the previous board by slotting the tongue and groove edges together. This is repeated for the first row of boards.
7. When installing the next rows, maintain a staggered pattern so as to have no continuous vertical joints – a staggering pattern of 600mm is recommended. The wall tie position should not coincide with a vertical joint. Please see further information in section 11 on starting the staggering pattern in corners.
8. Continue to construct the cavity wall and install insulation following the previous steps, ensuring excess mortar is removed from the cavity face and a cavity board is used to prevent mortar dropping on the top edge of the insulation.
9. If installation of the insulation boards is terminated below the highest level of the wall, the top edge of the insulation must be protected by a cavity tray and alternate perpendicular joints raked out, to provide adequate drainage of water from the tray.
10. Care should be taken to avoid:
  - a. any damage to the board during installation.
  - b. piercing the foil facing of the insulation board with the wall tie. This is a potential point of moisture ingress. Any damaged boards should be replaced.

## Corners

11. Figures 4, 5 & 6 show examples of external, internal and mitred corner details. Installation should take place as follows:

- Boards should be arranged in a 'blocking' arrangement, as shown in Figure 7, to ensure staggered corner edge joints.
- If the tongue of the board is exposed at the corner edge, this should be removed using a sharp specialist insulation saw or insulation knife (see bottom row corner board in Figure 7). There is no need to cut or fill the groove of the board when it is exposed at the corner edge.
- The boards at the corner should be butt-jointed. All presenting edges must be flush-cut by removing, at minimum, the groove or tongue. It is important that all cuts are accurate to ensure all edges are butted tightly with no air gaps, thus achieving continuity of the thermal envelope around the corners (see Figures 4,5 & 6).
- Where the boards 'interlock' as part of the blocking arrangement, a section of the tongue at the top of the lower board should be cut and removed, to ensure a flush fit with the board above.
  - Use a sharp specialist insulation saw or insulation knife to score the top of the tongue on board A by lining it up with the tongue edges and right hand edge of board B (as shown with the dotted lines X, Y & Z on Figure 8).
  - Cut through the tongue of board A and remove the sections of the tongue (areas 1 & 2 on Figure 8), leaving a 'residual rectangle' of tongue (Figure 9). Note: the cuts will have to be angled to reflect the tapered shape of the tongue (i.e. the top of the tongue is 40mm wide, the bottom is 50mm wide).
  - This will allow the overlapping tongue and groove edges of the upper and lower boards to fit flushly at the corner junction.
- When positioning the corner boards in a blocking arrangement, it is important to maintain the staggered pattern (detailed in section 7) required to avoid vertical joints on each row. Corner boards should be cut to size where necessary, taking into consideration the butt-joint, to achieve this.

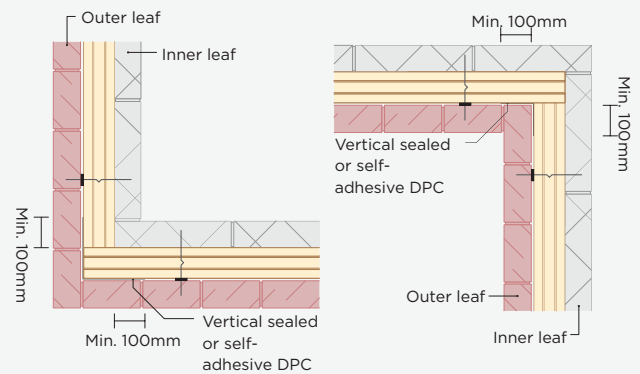

FIGURE 4 - EXTERNAL CORNER DETAIL

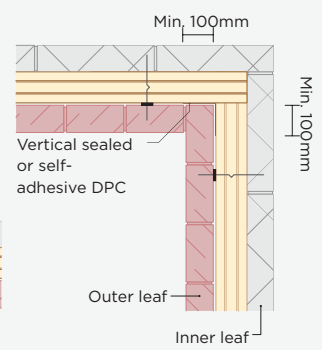

FIGURE 5 - INTERNAL CORNER DETAIL

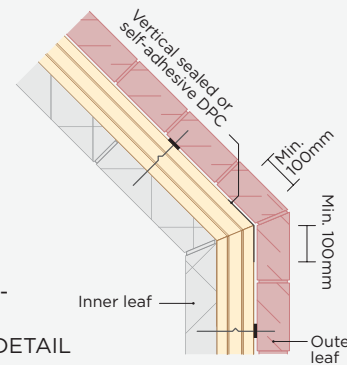

FIGURE 6 - MITRED CORNER DETAIL

FIGURE 7

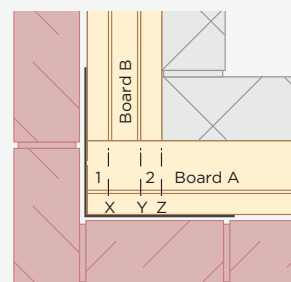
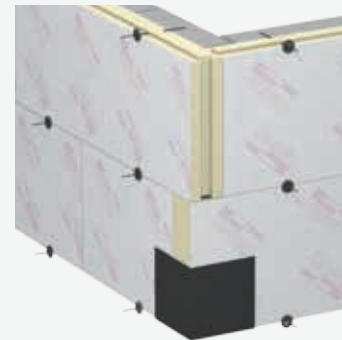

FIGURE 8

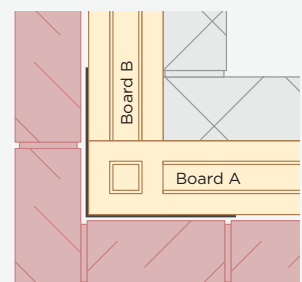

FIGURE 9

The building details are for illustrative purposes only. They do not constitute advice and should not be relied upon.

- All corner details should incorporate a vertical sealed or self-adhesive DPC with a minimum 100mm overlap beyond the board ends at all courses (see Figures 4, 5 & 6).  
To achieve this overlap, the width of the DPC should be selected based on the thickness of the board being installed.

## Openings

13. Where the Thermaclass Cavity Wall 21 insulation boards are required to be fitted around openings, the tongue and groove edge should be trimmed using a sharp specialist insulation saw or insulation knife. It is important that the tongue edge is cut accurately so that a tight butt edge is formed at the opening interfaces. To ensure a continuous layer of insulation is maintained, care should be taken to cut boards precisely and the cut pieces should be accurately and securely fitted to completely fill the space. Suitable damp proofing in accordance with regulations should be used around openings and any moisture should be directed to the external face of the building.

12. Positioning of wall ties in corner details should be in accordance with:
  - the engineer's specifications or
  - Eurocode 6, BS EN 845-1 and Building Regulations Approved Document A

14. Positioning of wall ties around openings should be in accordance with:
  - the engineer's specifications or
  - Eurocode 6, BS EN 845-1 and Building Regulations Approved Document A

Care should be taken to avoid damaging boards when fitting the extra wall ties around openings into the tongue and groove edge.
15. Specialist advice should be sought on the correct use of insulated cavity closers to ensure effective fire and thermal performance of the wall in accordance with the detailed requirements of the construction.

## General Information

- It is critical that all works are detailed in accordance to BBA certificate 16/5343 for Thermaclass Cavity Wall 21 Insulation for Full Fill Cavity Walls, which is available at [insulation-UK.com/BBA](http://insulation-UK.com/BBA).
- Eye protection and face masks should be worn at all times when handling/installing the boards. In addition, gloves should be worn when cutting boards or handling cut boards.
- Aluminium foil edges may be sharp so avoid sliding bare hands along board edges.
- Dust or particles in the eyes should be washed out with liberal quantities of water. If skin is sensitive to fibre irritation, apply a barrier cream to exposed areas before handling.
- Site conditions should be well ventilated.
- When cutting the boards, use a sharp specialist insulation saw or insulation knife. Use a straight edge to ensure an accurate butt edge or mitre joint.
- Thermaclass Cavity Wall 21 insulation boards should not be installed when the temperature is at or below 4°C and falling.
- Ensure that all exposed areas of insulation are protected with a weatherproof material or board when work is suspended or during rain.
- The boards must not be exposed to open flame or other ignition sources, or to solvents or other chemicals
- Take care not to drop boards; any damaged boards should not be used.
- The boards feature a branded foil facer on one side and an unbranded facer on the other. This is for cosmetic reasons only – there is no performance variation between these facers. In maintaining the defined orientation of the boards (see section 3), the wall will feature a mixture of branded and unbranded facers facing outward.
- Seek advice from a wall tie manufacturer for the most suitable tie for the construction.

## Storage

Thermaclass Cavity Wall 21 must be protected from prolonged exposure to sunlight. It should be stored dry, flat and raised above ground level (to avoid contact with ground moisture).

Where possible, packs should be stored inside. If stored outside, they should be under cover, or protected with opaque polythene sheeting. If boards are stored under tarpaulins, care should be taken to prevent rope damage.

Only as much material as can be installed during a single working period should be removed from storage at any one time.

## Waste Management and Recycling

Celotex continually monitors the levels of waste from its activities and drives and implements procedures which reduce the amount produced. The company ensures that all employees are aware of the importance of reducing waste in all activities.

The majority of Celotex products are packaged without the requirement for shrink wrap and instead use recyclable materials such as cardboard banding. Waste PIR is inert and

landfill safe with no known effect on ground water. Glass fibre used as core reinforcement in certain products is made up almost entirely from recycled waste glass.

For further information on the Sustainability credentials of Celotex, please visit [insulation-uk.com/about/corporate-and-social-responsibility](https://www.insulation-uk.com/about/corporate-and-social-responsibility)



**CELOTEX**

Lady Lane Industrial Estate,  
Hadleigh IP7 6BA

**Customer Service -  
Order Placement and Enquiries**

Tel: 01473 820820

Email: [iukcustomerservice@saint-gobain.com](mailto:iukcustomerservice@saint-gobain.com)

**Technical Support Centre**

Tel: 01473 820850

Email: [technicalsupport@saint-gobain.com](mailto:technicalsupport@saint-gobain.com)

**[insulation-uk.com](http://insulation-uk.com)**

Published date: May 2021

Document reference: 001-406

Celotex reserves the right to amend or revise product specification without notice. The information in this publication is correct at the time of publication. The information herein should not be read in isolation as it is meant only as guidance for the user, who should always ensure that they are fully conversant with the products and systems being used and their subsequent installation prior to the commencement of work.

For an up-to-date library of product information, users should visit the website at [insulation-uk.com](http://insulation-uk.com)

CELOTEX: Lady Lane Industrial Estate, Hadleigh, Ipswich, Suffolk, IP7 6BA. Tel +44 (0) 1473 822093.  
Saint-Gobain Construction Products UK Limited trading as Celotex, Registered in England. Company Number 734396.  
Registered Office: Saint-Gobain House, East Leake, Loughborough, Leicestershire LE12 6JU.